

⊖ Negative pole

⊕ Positive pole

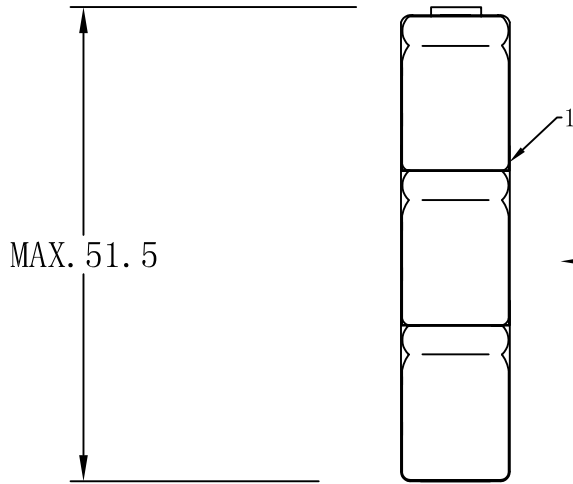

⊕
ESP-7-49-718J
NiMH Rechargeable
3.6V 300mAh
Must be Recycled or
Disposed of Properly
⊗

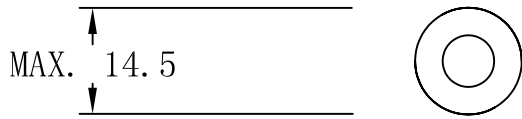
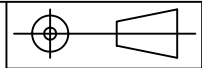
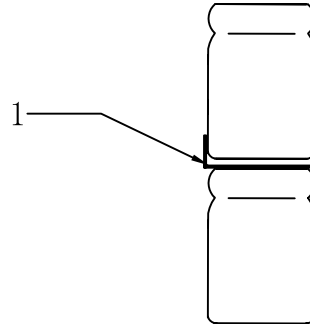

Weld Schematic Drawing

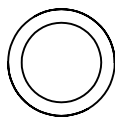

Remarks: 1) Three cells welded as drawing.

* 2) Black shrink sleeve for battery pack and the outer shrink sleeve is printed as drawing.

⊕
ESP-7-49-718J
NiMH Rechargeable
3.6V 300mAh
Must be Recycled or
Disposed of Properly
⊗

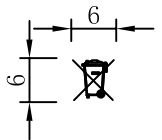

Item No.	materials	Quantity	Type and Size
1	Connective plate	2pcs	25×5×0.13

PO/NO	ESP-7-49-718J		NI-MH 1/3AAX3 3.6V 300mAh	Drawing NO.	3 * 1/3AA WITH + CONNCTACT
	Signature	Date		Dimmision	mm
Drawn by				Scale	1:1
Approved by				Ver	1